

*E-Vision Laser WQ120 Series*

---

**Important Information**



## Digital Projection

---

### Digital Projection Limited

Greenside Way, Middleton  
Manchester M24 1XX, UK

*Registered in England No. 2207264*  
*Registered Office: as above*

Tel (+44) 161 947 3300  
Fax (+44) 161 684 7674

enquiries@digitalprojection.co.uk  
service@digitalprojection.co.uk

www.digitalprojection.co.uk

### Digital Projection Inc.

55 Chastain Road, Suite 115  
Kennesaw, GA 30144, USA

Tel (+1) 770 420 1350  
Fax (+1) 770 420 1360

powerinfo@digitalprojection.com  
www.digitalprojection.com

### Digital Projection China

中国 北京市 朝阳区 芍药居北里101号  
世奥国际中心A座2011室(100029)

Rm A2011  
ShaoYaoJu 101 North Lane  
Shi Ao International Center  
Chaoyang District  
Beijing 100029, PR CHINA

Tel (+86) 10 84888566  
Fax (+86) 10 84888566-805

techsupport@dp-china.com.cn  
www.dp-china.com.cn

### Digital Projection Asia

16 New Industrial Road  
#02-10 Hudson Technocentre  
Singapore 536204

Tel (+65) 6284-1138  
Fax (+65) 6284-1238

www.digitalprojectionasia.com

# Super High Brightness Digital Video Projector

## Important Information

### Contents

Symbols used in the User Manual.....	4
Electrical and physical specifications.....	5
Laser precautions.....	5
Product labels.....	6
<i>Label locations</i> .....	7
Location of laser aperture.....	8
Interlock switches.....	8
General precautions.....	9
Installation precautions.....	10
Operation and configuration precautions.....	11
Compliance with international standards.....	11
<i>RF Interference</i> .....	11
<i>Noise</i> .....	11
<i>European Waste Electrical and Electronic Equipment (WEEE) Directive</i> .....	11
Basic Operation Instructions.....	12
<i>Positioning the screen and projector</i> .....	12
<i>Connecting the power supply</i> .....	13
<i>Switching the projector on</i> .....	14
<i>Switching the projector off</i> .....	14
<i>Selecting an input signal</i> .....	14
<i>Selecting a test pattern</i> .....	15
<i>Adjusting the lens</i> .....	15
<i>Adjusting the image</i> .....	15
<i>Inserting a new lens</i> .....	16
<i>Removing the lens</i> .....	17
Control Panel Reference.....	18
<i>Projector indicators</i> .....	19
Remote Control Reference.....	20

Full information about operating, connecting and setting up the projector can be found in the User Manual, located on the CD.

Updates may be available online - visit the Digital Projection website for all latest documents.

## Symbols used in the User Manual

---



**LASER WARNING:** this symbol indicates that there is a potential hazard of eye exposure to laser radiation unless the instructions are closely followed.



**ELECTRICAL WARNING:** this symbol indicates that there is a danger of electrical shock unless the instructions are closely followed.



**WARNING:** this symbol indicates that there is a danger of physical injury to yourself and/or damage to the equipment unless the instructions are closely followed.



**NOTE:** this symbol indicates that there is some important information that you should read.



*Specifications are subject to change without notice.*

## Electrical and physical specifications

Main Voltage	100-240 VAC 50/60Hz (Switch selectable)
Operating Temperature	0°C to 40°C (32 F to 104 F)
Storage Temperature	-20°C to 60°C (-4 F to 140 F)
Operating Humidity	Max 90% non-condensing
Dimensions:	W 500 mm (19.7 in), H 218 mm (8.6 in), D 598 mm (23.5 in)
Weight	27.2 kg (60 lb) without lens
Power Consumption	at 100 VAC: 890 W max
	at 240 VAC: 850 W max
	Standby power: < 6W (normal), <3W (ECO), <0.5W (Super Eco)
Thermal Dissipation	at 100 VAC: 3036.8 BTU/Hour max
	at 240 VAC: 2900.3 BTU/Hour max

## Laser precautions



### CLASS 3R LASER PRODUCT

This Laser Product is designated as Class 3R during all procedures of operation.

**LASER LIGHT - AVOID DIRECT EYE EXPOSURE.**

**Do not point laser or allow laser light to be directed or reflected toward other people or reflective objects.**

**Direct or scattered light can be hazardous to eyes and skin.**

**There is a potential hazard of eye exposure to laser radiation if the included instructions are not followed.**

**Caution – use of controls or adjustments or performance of procedures other than those specified herein may result in hazardous radiation exposure.**

### Laser Parameters:

Wavelength 450nm - 460nm (Blue) (\*typical 455nm)  
 Mode of operation Pulsed, due to frame rate  
 Pulse width 60Hz: 717.34us (73% output for blue segment)  
 Pulse width 50Hz: 861.11us (73% output for blue segment)  
 Pulse repetition rate 60Hz: 240Hz  
 Pulse repetition rate 50Hz: 200Hz  
 Maximum laser energy 0.376mJ  
 Total internal power 240Wmax (continuous laser output)  
 Apparent source size >14.7mm, at lens stop

### Divergence:

Lens	pos	0.64" WQXGA	
		V (Vertical)	H (Horizontal)
UWZ	WIDE	21.1	31.6
	TELE	17.1	26.3
WZ	WIDE	13.0	20.4
	TELE	9.3	14.7
STD	WIDE	9.6	15.1
	TELE	7.3	11.6
SLZ	WIDE	7.5	11.9
	TELE	4.5	7.2

Product labels

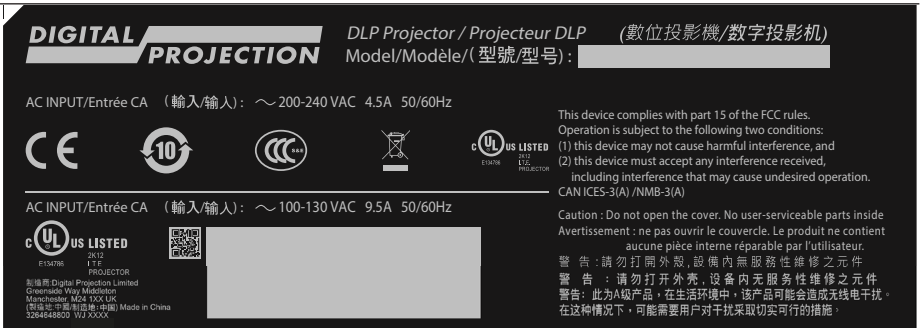

1 Manufacturer's ID Label



2 Explanatory Label and Certification Statement Label



3 Hazard Warning Symbol and Aperture Label

Label locations

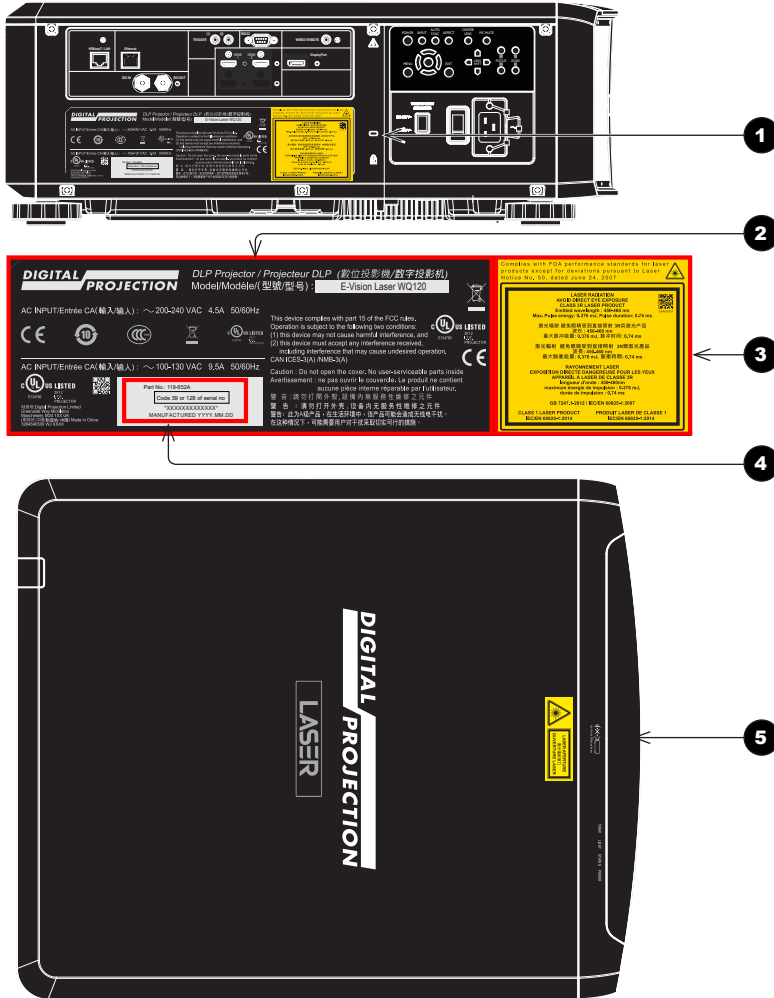

- 1 Location of Manufacturer's ID Label, Certification Statement Label and Explanatory Label on the body of the projector
- 2 Manufacturer's ID Label (manufacturer's name, address and projector model)
- 3 Certification Statement Label and Explanatory Label
- 4 Serial number
- 5 Location of Hazard Warning Symbol and Aperture Label on the body of the projector

## Location of laser aperture

---

The laser aperture is located as indicated below.

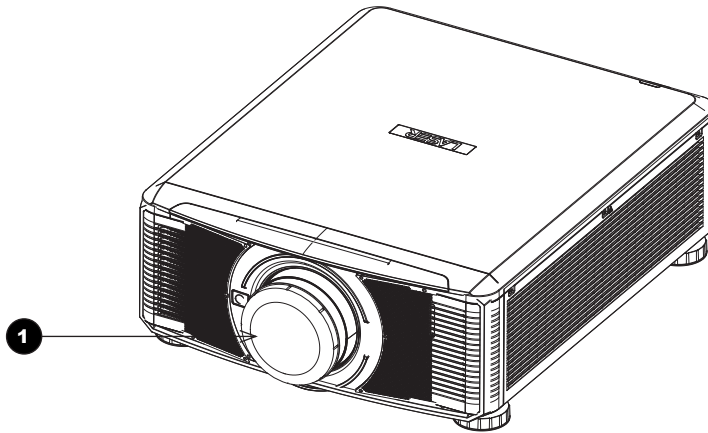

- 1** Laser aperture

## Interlock switches

---

Three interlock switches installed at the main frame, inside the cover, will power-off the system individually when activated.

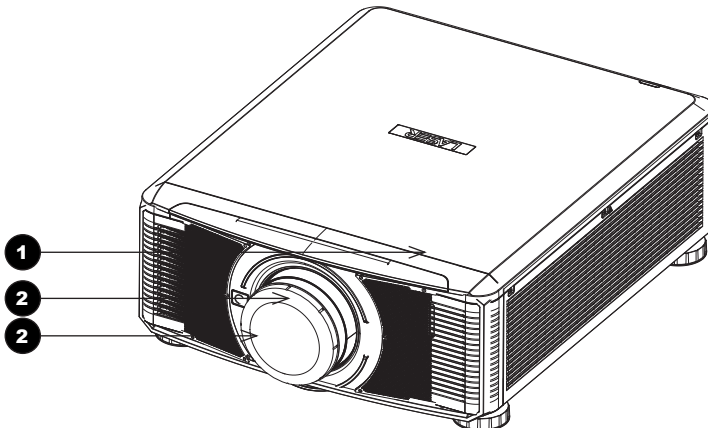

- 1** Will be activated when the top cover is removed.
- 2** x2. Will be activated when the projection lens is removed.



## General precautions



- The unit is never to be operated if the unit is defective or the cover or seal is damaged.
- No maintenance allowed by end user.
- Do not open the cabinet. There are no user serviceable parts inside.
- No service is allowed except by authorized personnel.
- Use only the power cable provided.
- Ensure that the power outlet includes a Ground connection, as this equipment **MUST** be earthed.
- Take care to prevent small objects such as paper or wire from falling into the projector.
- If this does happen, switch off immediately, and have the objects removed by authorised service personnel.
- Do not expose the projector to rain or moisture, and do not place any liquids on top of the projector.
- Unplug before cleaning, and use a damp, not wet, cloth.
- Do not touch the power plug with wet hands.
- Do not touch the power plug during a thunder storm.
- Handle the power cable carefully and avoid sharp bends. Do not use a damaged power cable.



- Do not touch the ventilation outlets, as they will become hot in use.
- Do not cover or obstruct the ventilation outlets or inlets.
- Do not cover the lens whilst the projector is switched on. This could cause a fire
- Always allow the projector to cool for 5 minutes before disconnecting the power or moving the projector.
- Never use strong detergents or solvents such as alcohol or thinners to clean the projector and lens.
- RISK GROUP 2 CAUTION.** Possibly hazardous optical radiation emitted from this product. Do not stare at operating light source. May be harmful to the eyes.



## Installation precautions



Connect the LAN cable only to a computer LAN connection. Other similar connectors may have a dangerously high voltage source.

The projector must be installed only by suitably qualified personnel, in accordance with local building codes.

The projector should be installed as close to the power outlet as possible.

The power connection should be easily accessible, so that it can be disconnected in an emergency.

Ensure that there is at least 50cm (19.7in) of space between the ventilation outlets and any wall, and 30cm (11.8in) on all other sides.

Do not install the projector close to anything that might be affected by its operational heat, for instance, polystyrene ceiling tiles, curtains etc.

Place the projector in a dry area away from sources of dust, moisture, steam, smoke, sunlight or heat.

The projector is heavy. Use safe handling techniques when lifting the projector.

Do not drop or knock the projector.

Before installation, make sure that the surface, ceiling or rigging that is to support the projector is capable of supporting the combined weight of the projector and lens.

When stacking projectors, the stack **MUST** be vertical, to ensure that the stresses are distributed to all four chassis corners.

Do not stack more than 3 projectors.

Do not place heavy objects on top of the projector chassis. Only the chassis corners and the optional rigging frame are capable of withstanding the weight of another projector.

Backup safety chains or wires should always be used with ceiling mount installations.

The projector can be operated in any position. It is recommended to position the projector in portrait mode with inputs facing upward, as shown in the diagram:

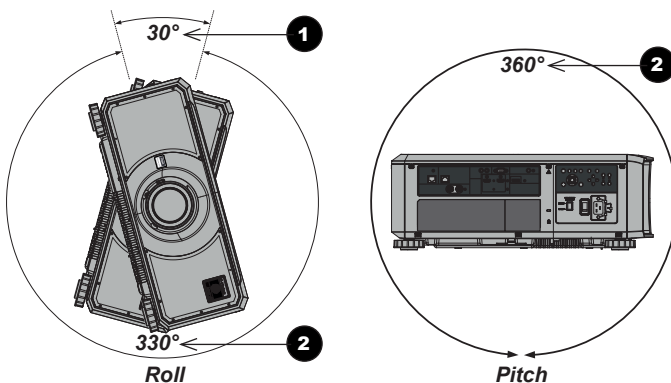

- 1** Recommended positions: inputs side up
- 2** Also possible

## Operation and configuration precautions

---



Do not make changes to the networking configuration unless you understand what you are doing, or have taken advice from your Network Manager. If you make a mistake, it is possible that you will lose contact with the projector. Always double-check your settings before pressing the APPLY button. Always keep a written note of the original settings, and any changes you have made.

Software updates should NOT be carried out except by, or with the supervision of, Digital Projection Service personnel.

## Compliance with international standards

---



### RF Interference

#### FCC

The Federal Communications Commission does not allow any modifications or changes to the unit EXCEPT those specified by Digital Projection in this manual. Failure to comply with this government regulation could void your right to operate this equipment.

This equipment has been tested and found to comply with the limits for a Class A digital device, pursuant with Part 15 of the FCC Rules. These limits are designed to provide reasonable protection against harmful interference when the equipment is operated in a commercial environment. This equipment generates, uses, and can radiate radio frequency energy and, if not installed and used in accordance with the instruction manual, may cause harmful interference to radio communications. Operation of this equipment in a residential area may cause harmful interference, in which case the user will be responsible for correcting any interference.

### Noise

#### GSGV Acoustic Noise Information Ordinance

The sound pressure level is less than 40 dB (A) according to ISO 3744 or ISO 7779.

## European Waste Electrical and Electronic Equipment (WEEE) Directive



Digital Projection Ltd is fully committed to minimising Waste Electrical and Electronic Equipment. Our products are designed with reuse, recycling and recovery of all components in mind. To this end, at end of life, your projector may be returned to Digital Projection Ltd or its agent so that the environmental impact can be minimised.

## Basic Operation Instructions

### Positioning the screen and projector

1. Install the screen, ensuring that it is in the best position for viewing by your audience.
2. Mount the projector, ensuring that it is at a suitable distance from the screen for the image to fill the screen. Set the adjustable feet so that the projector is level, and perpendicular to the screen.

The drawing below shows the positions of the feet for table mounting, and the fixing holes for ceiling mounting.

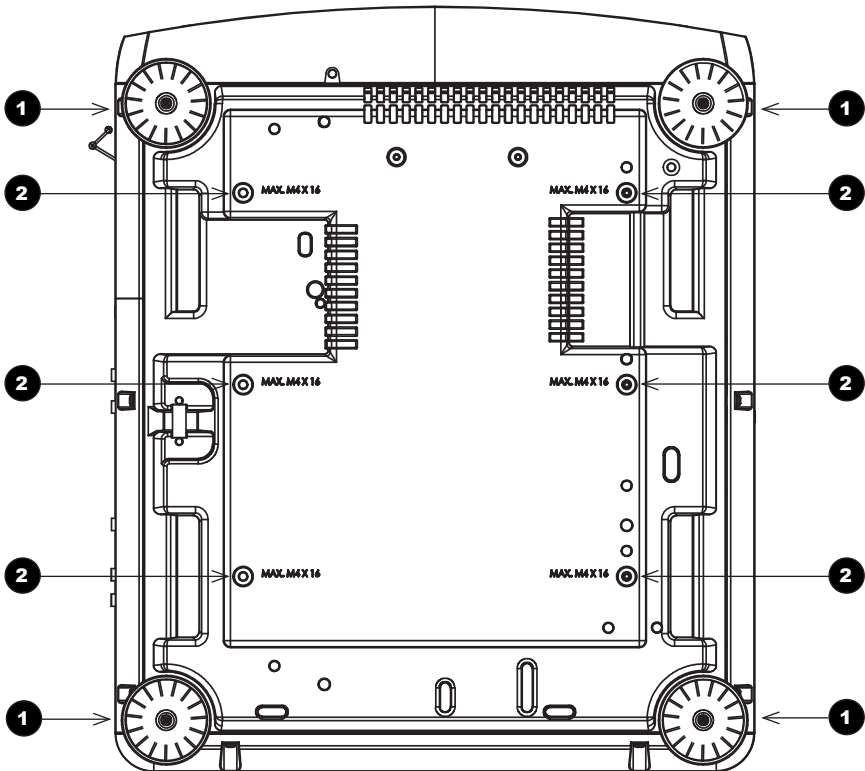

**1** Four adjustable feet

**2** Six M4 holes for ceiling mount  
The screws should not penetrate more than 15 mm into the body of the projector.

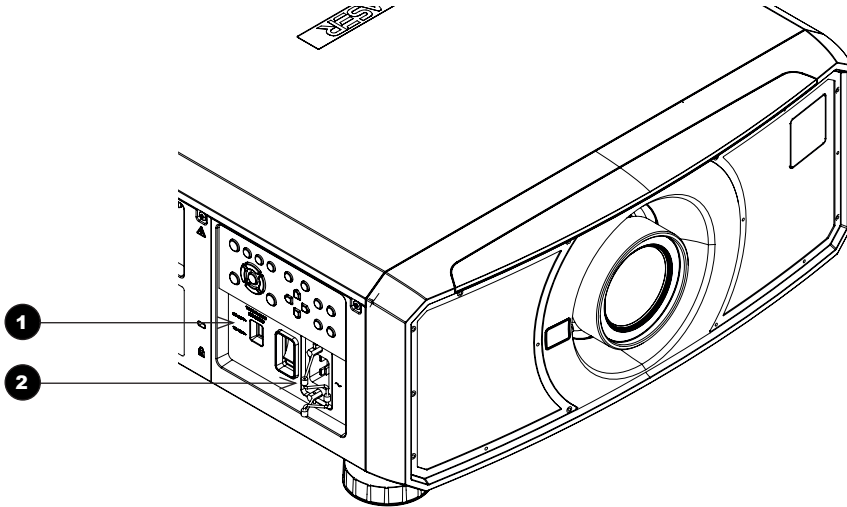

## Connecting the power supply

Adjust the **VOLTAGE SELECT switch** **1** to the required voltage, then firmly push the mains connector into the **socket** **2**.



### Voltage selection

The VOLTAGE SELECT switch must be set to match the power supply you are using:

Voltage of power supply used	Position of VOLTAGE SELECT switch
100-130VAC outlet	200 240V~  100 130V~
200-240VAC (single phase) outlet	200 240V~  100 130V~



Use only the power cable provided.

Ensure that the power outlet includes a ground connection as this equipment **MUST** be earthed.

Handle the power cable carefully and avoid sharp bends. Do not use a damaged power cable.

## Switching the projector on

1. Connect the power cable between the mains supply and the projector. (See **Connecting the power supply** above.) Switch on at the switch next to the power connector.
2. The **POWER** indicator lights red to signal that the projector is in STANDBY mode. Press one of the following buttons:
  - On the remote control, the **ON** button
  - On the projector control panel, the **POWER** button.

The fans begin working, then the **POWER** indicator begins flashing green. When the flashing stops, the **POWER** and **LIGHT** indicators both light steady green. The projector is switched on.

## Switching the projector off

1. Press **OFF** on the remote control or **POWER** on the control panel, then press again to confirm your choice.

The **POWER** indicator on the control panel will start flashing amber, the system will go out and the cooling fans will run for a short time until the **POWER** indicator goes steady red to indicate that the projector has entered STANDBY mode.

2. If you need to switch the projector off completely, switch off at the mains power switch next to the power connector and then disconnect the power cable from the projector.

## Selecting an input signal

1. Connect one or more image sources to the projector.
2. Select the input you want to display:
  - Press one of the input buttons on the remote control.
  - Alternatively, open the On-screen display (OSD) by pressing **MENU**. Highlight **Input** from the main menu, press **ENTER/OK** and then select an input signal using the **UP** and **DOWN** arrow buttons. Press **ENTER/OK** to confirm your choice.

## Selecting a test pattern

To display a test pattern:

- Press **TEST** on the remote control. If necessary, press again to change the test pattern. Test patterns are displayed in the following order:

**White, Black, Red, Green, Blue, Off**

After the final test pattern, the projector exits test pattern mode and returns to the main image. To view test patterns again, you need to press **TEST** again.

- Alternatively, open the OSD by pressing **MENU**. Highlight **Test Patterns** from the main menu, then select a test pattern using the **LEFT** and **RIGHT** arrow buttons.

## Adjusting the lens

The lens can be adjusted using the **Lens** menu, or using the lens buttons on the remote control.

### *Lens menu*

The **Lens** menu provides access to the **Lens Control** setting and the **Center Lens** command.

**Lens Control** allows **Zoom**, **Focus** and **Shift** adjustment using the arrow buttons. The setting operates in **Zoom/Focus Adjustment** and **Shift Adjustment** mode.

Press **ENTER/SELECT** to switch between the two modes.

### *Remote control*

Use the remote control to adjust zoom, focus and shift directly, without opening a menu:

- **OK** enters lens control, then switches between **Zoom/Focus Adjustment** and **Shift Adjustment**.
- **EXIT** exits lens control and opens the **Lens** menu.
- **MENU** exits lens control and returns to the main image.
- The arrow buttons adjust zoom, focus and shift as indicated on the screen.

## Adjusting the image

### *Orientation*

- This can be set from the **Setup** menu.

Highlight Projector Mode and choose from **Front Tabletop**, **Front Ceiling**, **Rear Tabletop**, **Rear Ceiling** and **Auto-front**.

### *Picture*

- Settings such as **Gamma**, **Brightness**, **Contrast**, **Saturation**, **Hue** and **Sharpness** can be set from the **Image** menu.

## Inserting a new lens



Before changing the lens, always make sure the projector is switched off and fully disconnected from its power supply.



When changing the lens, avoid using excessive force as this may damage the equipment.



*The lens is shipped separately.*



*Take care to preserve the original lens packaging and protective caps for future use.*



*The projector will not power on without the lens fitted.*

1. Remove the lens cap.

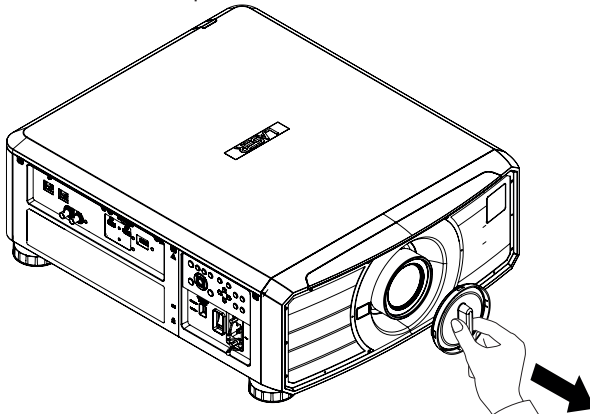

2. Position the lens so that the labels are at the top, and gently insert it all the way into the lens mount.
3. Push the lens in firmly, and turn it clockwise until it clicks into place.

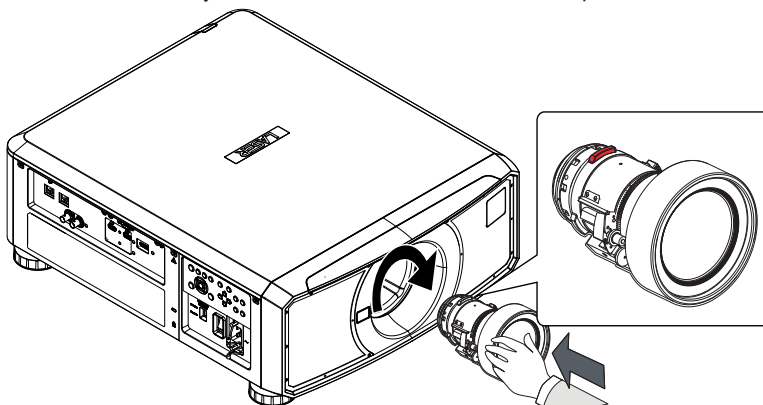



## Removing the lens



Before changing the lens, always make sure the projector is switched off and fully disconnected from its power supply.



When changing the lens, avoid using excessive force as this may damage the equipment.



*The lens is shipped separately.*



*Take care to preserve the original lens packaging and protective caps for future use.*



*The projector will not power on without the lens fitted.*

1. Push in the lens release lever, and turn the lens anti-clockwise.
2. Remove the lens.

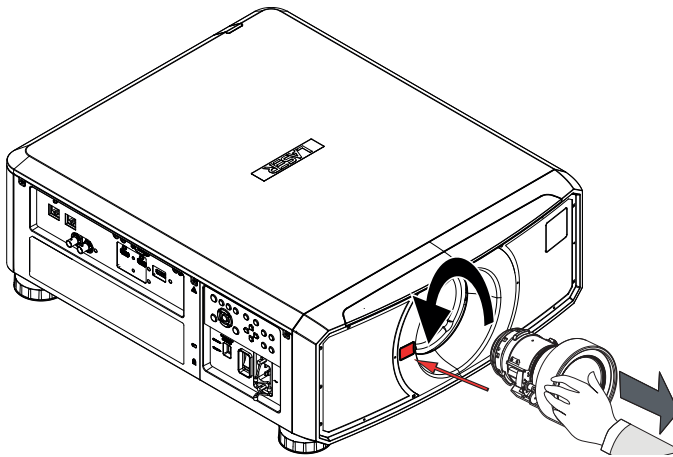

### Control Panel Reference

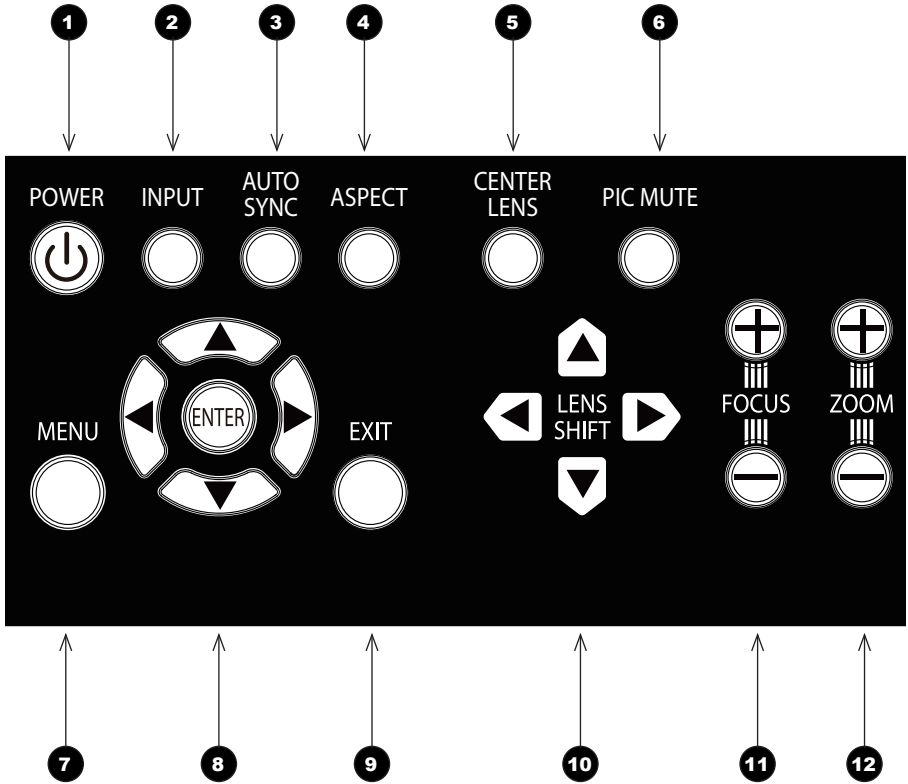

- 1 POWER**  
Switches the projector on and off (STANDBY).
- 2 INPUT**  
Switches to the next input source.
- 3 AUTO SYNC**  
Re-synchronises with the current input signal.
- 4 ASPECT**  
Changes the aspect ratio.
- 5 CENTER LENS**  
Centers the lens.
- 6 PIC MUTE**  
Switches the laser off/on.
- 7 MENU**  
Displays and exits the OSD.
- 8 Arrow buttons & ENTER**  
Navigation buttons used to highlight menu entries in the OSD.  
Press **ENTER** to open or execute the highlighted menu entry.
- 9 EXIT**  
Exits the current OSD page and enters the level above.
- 10 LENS SHIFT arrow buttons**  
Each of these buttons moves the lens in the specified direction.
- 11 FOCUS plus and minus buttons**  
Used to move the focus in and out.
- 12 ZOOM plus and minus buttons**  
Used to zoom in and out.

## Projector indicators

- TEMP.** Off = no problem  
Flashing red = temperature error
- LIGHT** Off = light is switched off  
Flashing green = light is preparing to switch on  
Flashing red (cycles of six flashes) = light module failure  
On, red = light module has reached end of life  
On, green = light is switched on
- STATUS** Off = no problem  
Flashing red (continuously) = cover error  
Flashing red (cycles of four flashes) = fan error  
On, red = system error
- POWER** Off = the projector is switched off  
Flashing green = the projector is warming up  
Flashing amber = the projector is cooling down  
On, red = STANDBY mode  
On, green = the projector is switched on

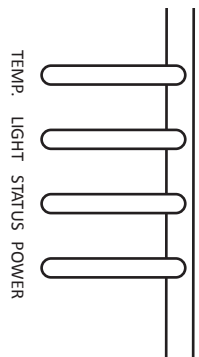

## Remote Control Reference

- 1 Power ON/OFF**  
Turns the projector on and off. To turn the projector off, press the OFF button twice within five seconds.
- 2 Pic Mute OPEN / CLOSE**  
Shows and hides the projected image.
- 3 OSD ON / OFF**  
Enables and disables screen timeout messages and showing the OSD during projection.
- 4 MENU**  
Access the projector OSD (on-screen display). If the OSD is open, press this button to go back to the previous menu.
- 5 Navigation (arrows and OK)**  
Navigate through the menus with the arrows, confirm your choice with **OK**. In lens adjustment modes, the arrows are used to move, zoom or focus the lens. See **11** below.  
In lens adjustment modes, or when the OSD is not showing, the **OK** button switches between modes: **Shift Adjustment** and **Zoom / Focus Adjustment**.
- 6 EXIT**  
Close the current OSD page and return to the level above.
- 7 FREEZE**  
Freeze the current frame.
- 8 DEFAULT**  
Restore default settings.
- 9 INFO**  
Access information about the projector.
- 10 RE-SYNC**  
Re-synchronise with the current input signal.

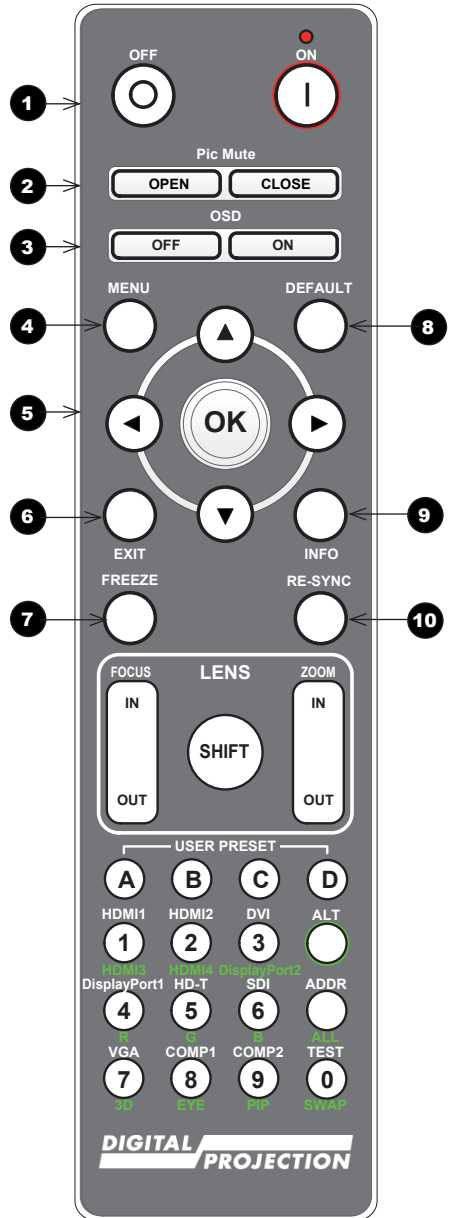

- 11** **LENS adjustment**  
**FOCUS IN / OUT:** adjust focus.  
**SHIFT:** press and hold this button, then use the Navigation arrow buttons to move the lens.  
**ZOOM IN / OUT:** adjust zoom.
  
- 12** **USER PRESET A, B, C, D**  
 Load user presets.
  
- 13** **ALT**  
 Press and hold this button to access alternative functions for all buttons with a green label.
  
- 14** **DVI / DisplayPort2 / numeric input 3**  
 There is no DVI input on this projector.  
 There is no DisplayPort 2 input on this projector.
  
- 15** **HDMI 2 / HDMI 4 / numeric input 2**  
 Select the HDMI 1 input.  
 There is no HDMI 4 input on this projector.
  
- 16** **HDMI 1 / HDMI 3 / numeric input 1**  
 Select the HDMI 1 input.  
 There is no HDMI 3 input on this projector.
  
- 17** **TEST / SWAP / numeric input 0**  
 Show a test pattern. Press again to show the next test pattern:  
**...Off, White, Black, Red, Green, Blue, Off...**

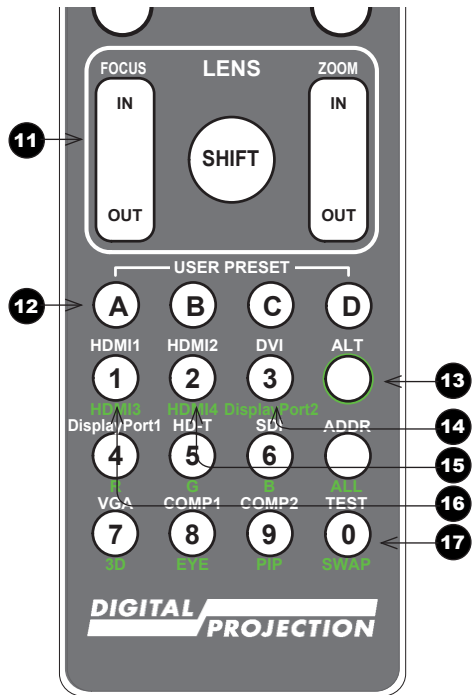

*This projector does not use the following options on the remote:*

*DVI, VGA, COMP 1, COMP 2, HDMI 3, HDMI 4 and DisplayPort2.*

**18** **DisplayPort1 /R/ numeric input 4**  
Select the DisplayPort 1 input.

**19** **HD-T /G/ numeric input 5**  
Select the HDBaseT input.

**20** **SDI /B/ numeric input 6**  
Select the 3G-SDI input.

**21** **VGA /3D/ numeric input 7**  
There is no VGA input on this projector.  
Use with **ALT** to toggle the **3D Format** setting between **Off** and **Auto**.

**22** **COMP1 /EYE/ numeric input 8**  
There is no Component 1 input on this projector.  
Use with **ALT** to switch between left and right eye 3D dominance.

**23** **COMP2 /PIP/ numeric input 9**  
There is no Component 1 input on this projector.

**24** **ADDR / ALL**  
Assign and unassign an IR remote address.

**To assign an address:**

1. Press and hold this button until the indicator starts flashing.
2. Release this button and while the indicator is still flashing, enter a two-digit address using the numeric input buttons. The indicator will flash three times quickly to confirm the change.

**To unassign an address and return to the default address 00,**

- Press and hold **ALT** and this button simultaneously until the indicator flashes to confirm the change.

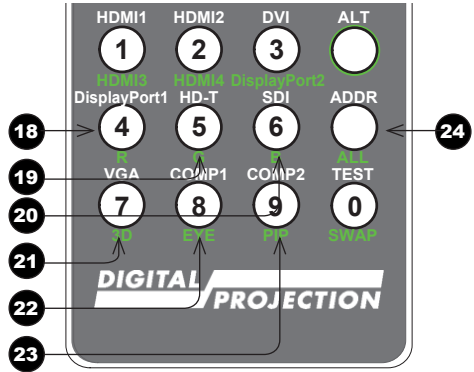

*This projector does not use the following options on the remote:*

*DVI, VGA, COMP 1, COMP 2, HDMI 3, HDMI 4 and DisplayPort2.*